

磁阻式/74系列 B型 (引线端子型)



主要参数 (main parameters)

推荐型号 (Recommended models)	J74XU9734A				
极对数 (Pole)	2	3	4	5	6
励磁电压 (Input voltage)	AC7Vrms				
励磁频率 (Input frequency)	10KHz				
变压比 (Transformation ratio)	0.286 ± 10%				
电气误差 (Accuracy)	60'	40'	30'	25'	20'
相位移 (Phase shift)	≤ 10°	≤ 10°	≤ 12°	≤ 8°	≤ 5°
输入阻抗 (Input impedance)	(100 ± 15) Ω	(120 ± 18) Ω	(80 ± 12) Ω	(100 ± 15) Ω	(80 ± 12) Ω
耐电压 (Dielectric strength)	AC 500V 1min				
允许最大转速 (Max operating speed)	20000 rpm				
工作温度范围 (Operating temperature range)	-40°C ~ +155°C				

外形及安装尺寸图 Outline (dimension:mm)

定子外形及安装尺寸图

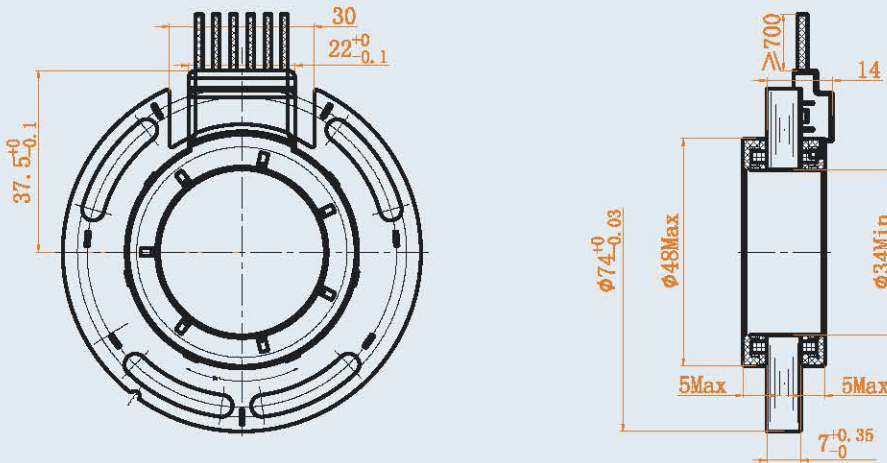

转子外形及安装尺寸图

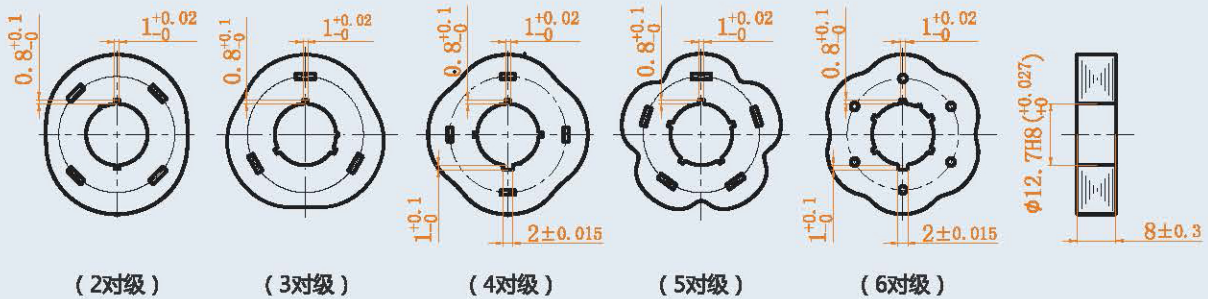

磁阻式 VR RESOLVER